

## WIRELESS BACKHAUL FOR

# LTE and Small Cell Networks



As network operators continue to build deployments that connect people in urban locations, the inherent advantages of wireless technology are compelling. Networks depend on reliable high-capacity backhaul at street level to support edge access solutions such as LTE or small cells. Without needing to trench or install cable, wireless systems can be deployed much faster and at a fraction of the total cost of a wired or fiber solution. However, in many cases – and particularly in urban locations – a clear Line of Sight (LoS) path for the wireless system is difficult to find. The objective is a reliable, cost effective wireless solution that performs well not only in LoS conditions, but also near Line of Sight (nLoS) and Non-Line of Sight (NLOS) applications.

A Malaysian network operator needed to provide LTE and small cell edge access at distances of 1 km or less in an urban location where there was no access to the fiber backbone. There was no LoS possible in the dense environment at street level, so the backhaul needed to perform in nLoS and NLoS conditions while meeting strict frame loss and throughput requirements.

The operator recently conducted field tests on alternative wireless solutions for connecting LTE and small cell networks, determining that Cambium Networks' PTP 670 provided consistently reliable performance in urban applications, and particularly when confronted with NLoS configurations.

## ARCHITECTURE

After having several wireless systems fail in either lab or field tests, the operator knew the exact application to test, collecting 30 days of experimental data evaluating LoS, nLoS, and NLoS performance over a distance of 1 km in the heart of a major urban area.

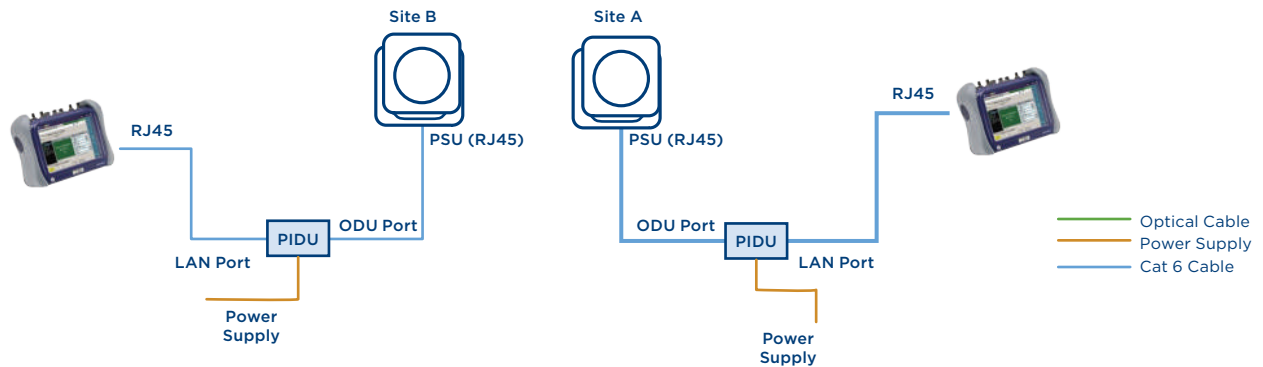

The location of the link end points was consistent and representative of the actual field deployment:

PTP MASTER SITE	SITE 1	SITE 2	SITE 3	SITE 4
90 M height on rooftop	Height 2m <b>Range 300 m</b> LoS – point 1 nLoS – point 2 NLoS – point 3	Height 2m <b>Range 400 m</b> LoS – point 4 nLoS – point 5 NLoS – point 6	Height 2m <b>Range 600 m</b> LoS – point 7 nLoS – point 8 NLoS – point 9	Height 2m <b>Range 700 m</b> LoS – point 10 nLoS – point 11 NLoS – point 12

For each location was planned using the free LINKPlanner software from Cambium Networks. LINKPlanner uses the exact GPS location of the source and destination elements, identifies obstructions, and estimates path performance of each link.

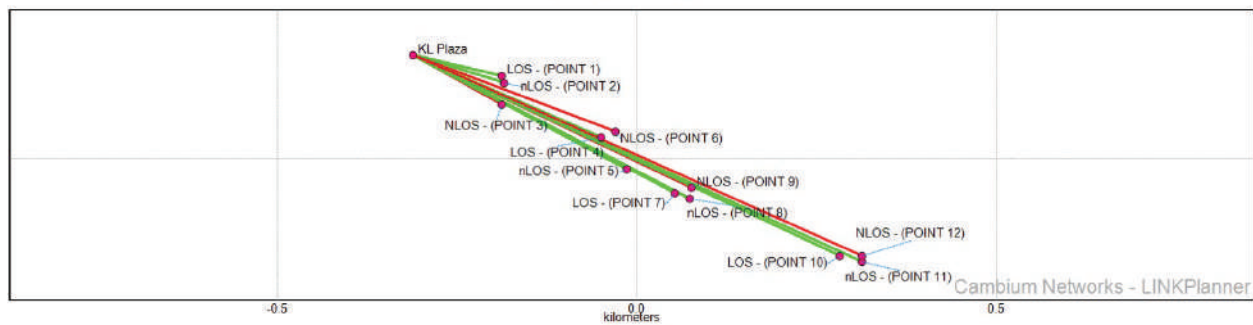

LINKPlanner software also provides a Google Earth overlay of the links to show the exact location of the links in the actual environment.



Master location



Remote Sites

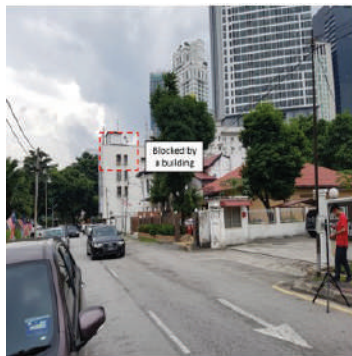
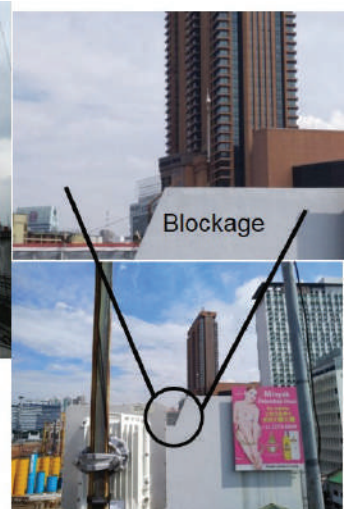

## PTP 670 TECHNOLOGY

Cambium Networks PTP 670 backhaul includes the following core technologies to improve performance in noisy or obstructed environments:

- Dynamic Spectrum Optimization™ (DSO) – a unique capability offered by Cambium Networks that enables optimization of link performance by automatically sampling and changing channels to avoid interference without affecting link service. See the DSO White Paper for full details.
- High Capacity Multipoint Connectivity (HCMP) – allows for up to 8 nodes (in roadmap) to connect a single master radio, opening new deployment models that simplify planning, enable rapid deployment, and provide a rapid return on investment.
- Security – PTP 670 has multiple layers of security to protect traffic.
  - 128-bit AES encryption
  - 256-bit AES encryption
  - Multi-level user authentication
  - Audit trail of security activity
  - RADIUS authentication
  - OOBM (Out-of-Band Management)
  - SNMPv3
  - Remote Password Maintenance
- Rugged Design
  - 200 mph wind survivability
  - IP 66/67 dust and water intrusion compliant
  - Salt Fog Environment test (MIL-STD-8010G)
  - Shock and Vibration test (MIL-STD-810G)

## TEST RESULTS

The tests on all of the above configurations were conducted, yielded the following observations:

- PTP 670 provided coverage for LOS, nLOS and NLOS conditions up to 1km from street level deployment.
- PTP 670 covers effectively for both diffractive and reflective NLOS conditions.
- PTP 670 met the customer's minimum requirement with regards to capacity, latency and frame loss below 0.005% at various deployment conditions (12 x Test points)
- **LOS: 100Mbps FD** is achieved as per minimum requirement with 99.995% availability
- **nLOS: 100Mbps FD** is achieved as per minimum requirement with 99.995% availability
  - Fresnel zone blocking from 20- 40% considered nLOS (near line of sight)
- **NLOS: 50Mbps FD** is achieved as per minimum requirement with 99.995% availability
  - Fresnel zone blocking 50% and above is considered as NLOS (Non line of sight)

## BUSINESS CONCLUSIONS

Based on the above measurements in a standard performance test, the evaluation team calculated the value to the business of deploying PTP 670 for edge access network backhaul:

- Estimated site acquisition time is reduced by 50% vs traditional microwave backhaul
- Estimated deployment/site turn up time is reduced by 70%
- Overall cost reduction for the equipment of 30%

## DETAIL FIELD PERFORMANCE TEST RESULTS

Site #3, at a distance of 600 meters, provided the most challenging NLoS conditions, particularly point 9 from the table above, for which the path between the master and the site was completely blocked by a building.

- The instance is shown on Google Earth – from above and from street level. This situation is typical for any major urban area.
- Also shown are the path predictions given by the LINKPlanner software.
- The results from the PTP 670 onboard Spectrum Analyzer depict the noise and available spectrum.
- Throughput tests exhibit no frame loss at any frame length tested.

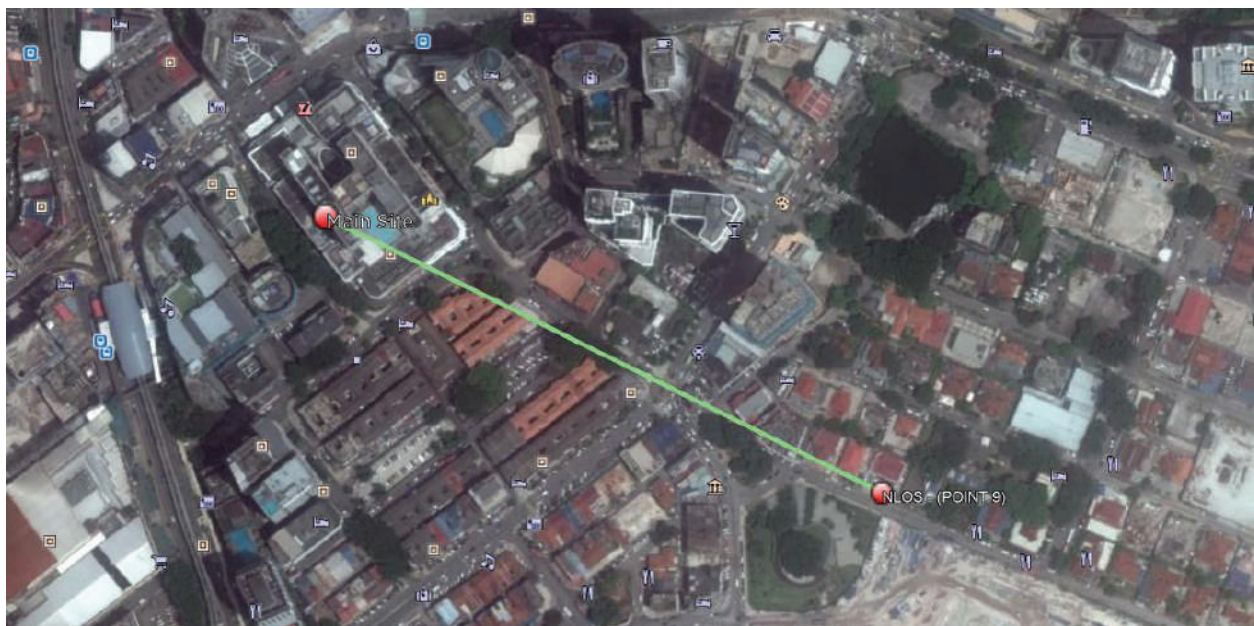



[Home](#)
[Status](#)

« System

» Configuration

Spectrum Expert

» Statistics

» Diagnostics Plotter

Cable Diagnostics

Software Upgrade

Reboot

» Installation

» Management

» Security

Change Password

Logout

### System Status - Master

#### Equipment

Attributes	Value	Units
Link Name	A to B	
Unit Name	A Master	
Site Name		
Software Version	50670-02-50	
Hardware Version	BOP01.01-I-FPS	
Unit ESN	00046680700	
Unit MSN	U9TE00HQ9NGS	
Regulatory Band	8 - 5.4 GHz - Other	
Elapsed Time Indicator	00:00:51	
Ethernet / Internet		
Aux Port Status	Copper Link Up	
Aux Port Speed And Duplex	1000 Mbps Full Duplex	
MAC Address	00:04:56:58:07:d0	
Remote Identification		
Remote Unit Name	B Slave	
Remote MAC Address		
Remote Internet Address		
TDD Synchronization		
TDD Synchronization Interface	Disabled	
Status Page Refresh Period	600	Seconds

#### Wireless

Attributes	Value	Units
Wireless Link Status	Up	
Wireless Link Up Time	00:00:08	
Wireless Encryption	None	
Maximum Transmit Power	27	dBm
Remote Maximum Transmit Power	27	dBm
Transmit Power	27.0, 23.2, -15.0, 24.0	dBm
Receive Power	-49.7, -77.6, -110.0, -52.9	dBm
Vector Error	7.2, -1.6, -29.6, -27.7	dB
Link Loss	123.1, 22.2, 0.0, 123.0	dB
Transmit Data Rate	99.27, 11.97, 0.00, 58.95	Mbps
Receive Data Rate	58.95, 9.89, 0.00, 58.95	Mbps
Link Capacity Variant	Full	
Link Capacity	126.73	Mbps
Wireless Link Availability	100.0000	%
Data Bridging Availability	100.0000	%
Transmit Modulation Mode	64QAM 0.92 (Single) (30 MHz)	
Receive Modulation Mode	64QAM 0.92 (Single) (30 MHz)	
Link Symmetry	Adaptive	
Receive Modulation Mode Detail	Running At User-Configured Max Modulation Mode	
Range	0.5	km

[Home](#)
[Status](#)

Alarms

» System

» Installation

» Management

» Security

Change Password

Logout

### System Status - Slave

#### Equipment

Attributes	Value	Units
Link Name	A to B	
Unit Name	B Slave	
Site Name	Slave	
Software Version	50670-02-50	
Hardware Version	BOP01.01-I-FPS	
Unit ESN	00046680887	
Unit MSN	U9TF0046755H	
Regulatory Band	8 - 5.4 GHz - Other	
Elapsed Time Indicator	00:01:33	
Ethernet / Internet		
Main PSU Port Status	Copper Link Up	
Main PSU Port Speed And Duplex	1000 Mbps Full Duplex	
Aux Port Status	Down	
Aux Port Speed And Duplex		
MAC Address		
Remote Identification		
Remote Unit Name	A Master	
Remote MAC Address		
Remote Internet Address		

#### Wireless

Attributes	Value	Units
Wireless Link Status	Up	
Wireless Link Up Time	00:00:31	
Wireless Encryption	None	
Maximum Transmit Power	27	dBm
Remote Maximum Transmit Power	27	dBm
Transmit Power	27.0, 25.8, -15.0, 24.0	dBm
Receive Power	-49.6, -75.2, -110.0, -53.2	dBm
Vector Error	7.2, -6.9, -29.8, -28.3	dB
Link Loss	125.2, 45.4, 0.0, 123.2	dB
Transmit Data Rate	58.95, 21.10, 0.00, 58.95	Mbps
Receive Data Rate	76.93, 21.93, 0.00, 58.95	Mbps
Link Capacity Variant	Full	
Link Capacity	126.73	Mbps
Wireless Link Availability	100.0000	%
Data Bridging Availability	100.0000	%
Transmit Modulation Mode	64QAM 0.92 (Single) (30 MHz)	
Receive Modulation Mode	64QAM 0.92 (Single) (30 MHz)	
Link Symmetry	Adaptive	
Receive Modulation Mode Detail	Running At User-Configured Max Modulation Mode	
Range	0.5	km

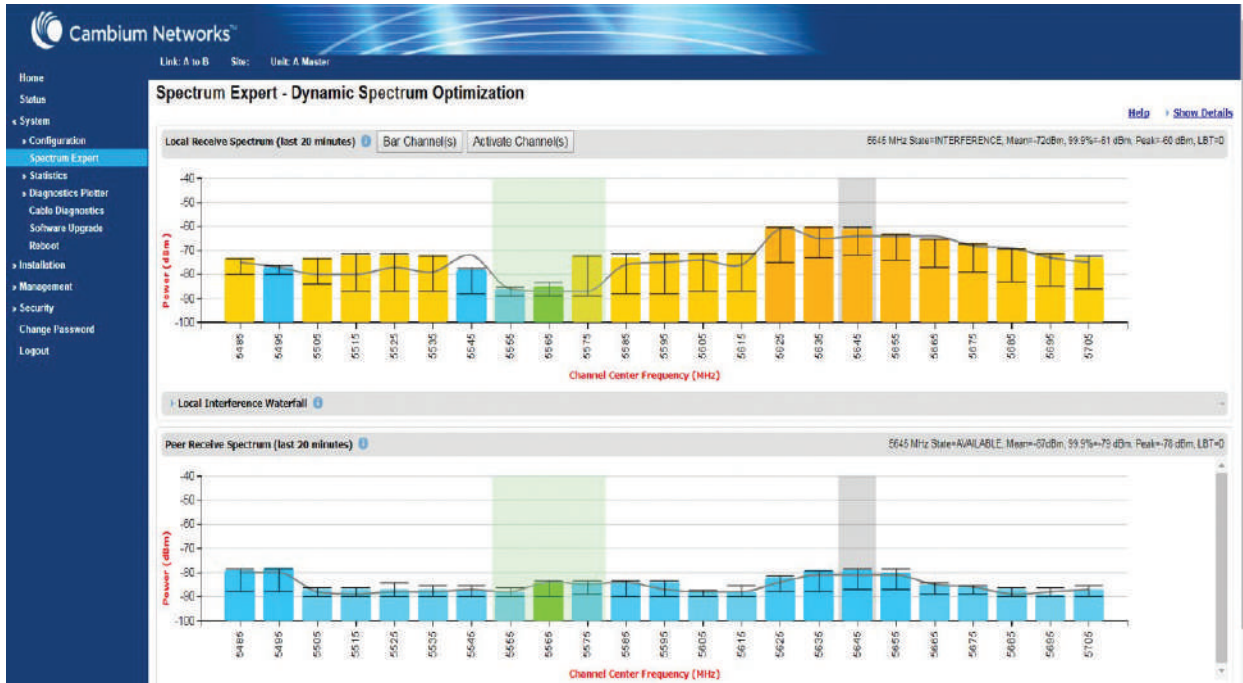

## THROUGHPUT TEST

Frame Length (Bytes)	Cfg Rate (L1 Mbps)	Measured Rate (Mbps)	Measured L1 (% of Line Rate)	Measured Rate (frms/sec)	Pause Detected	
64	50.00	L1	50.02	5.002	74430	No
		L2	38.11			
		L3	27.39			
		L4	15.48			
128	50.00	L1	50.02	5.002	42247	No
		L2	43.26			
		L3	37.18			
		L4	30.42			
256	50.00	L1	50.02	5.002	22652	No
		L2	46.40			
		L3	43.13			
		L4	39.51			
512	50.00	L1	50.02	5.002	11753	No
		L2	48.14			
		L3	46.45			
		L4	44.57			
1024	50.00	L1	50.02	5.002	5989	No
		L2	49.06			
		L3	48.20			
		L4	47.24			
1280	50.00	L1	50.02	5.002	4810	No
		L2	49.25			
		L3	48.56			
		L4	47.79			
1518	50.00	L1	50.02	5.002	4065	No
		L2	49.37			
		L3	48.78			
		L4	48.13			

No Frame Loss at any Frame Length



Cambium Networks, Ltd.  
3800 Golf Road, Suite 360,  
Rolling Meadows, IL 60008

Cambium Networks, the Cambium Networks logo, cnPilot and cnMaestro are trademarks of Cambium Networks, Ltd.

Copyright © 2018 Cambium Networks, Ltd. All rights reserved.